

MF500-HTS Series



Meet FPTI™'s newest innovation . . .

. . . the MF500-HTS Hydrostatic Transmission Training Simulator

Why the MF500-HTS should be in your lab:

- SAFE! - No exposed rotating parts, no wheels on the ground, and all hydraulic components are at waist height and in full view for safe, team-based learning.
- Use it to teach pump/motor install and pre-start procedures, mechanical and electronic adjustments, and flow and pressure adjustments.
- Amazing diagnostics capability - every conventional fault (wear or electric) a hydrostatic drive can experience is built into the system. Faults are automatically introduced by the PC-controlled software and displayed on a 19" touch-screen monitor with full-color display.
- Teach any make of transmission:
Sundstrand®, Rexroth®, Dennison®, Linde®, etc.

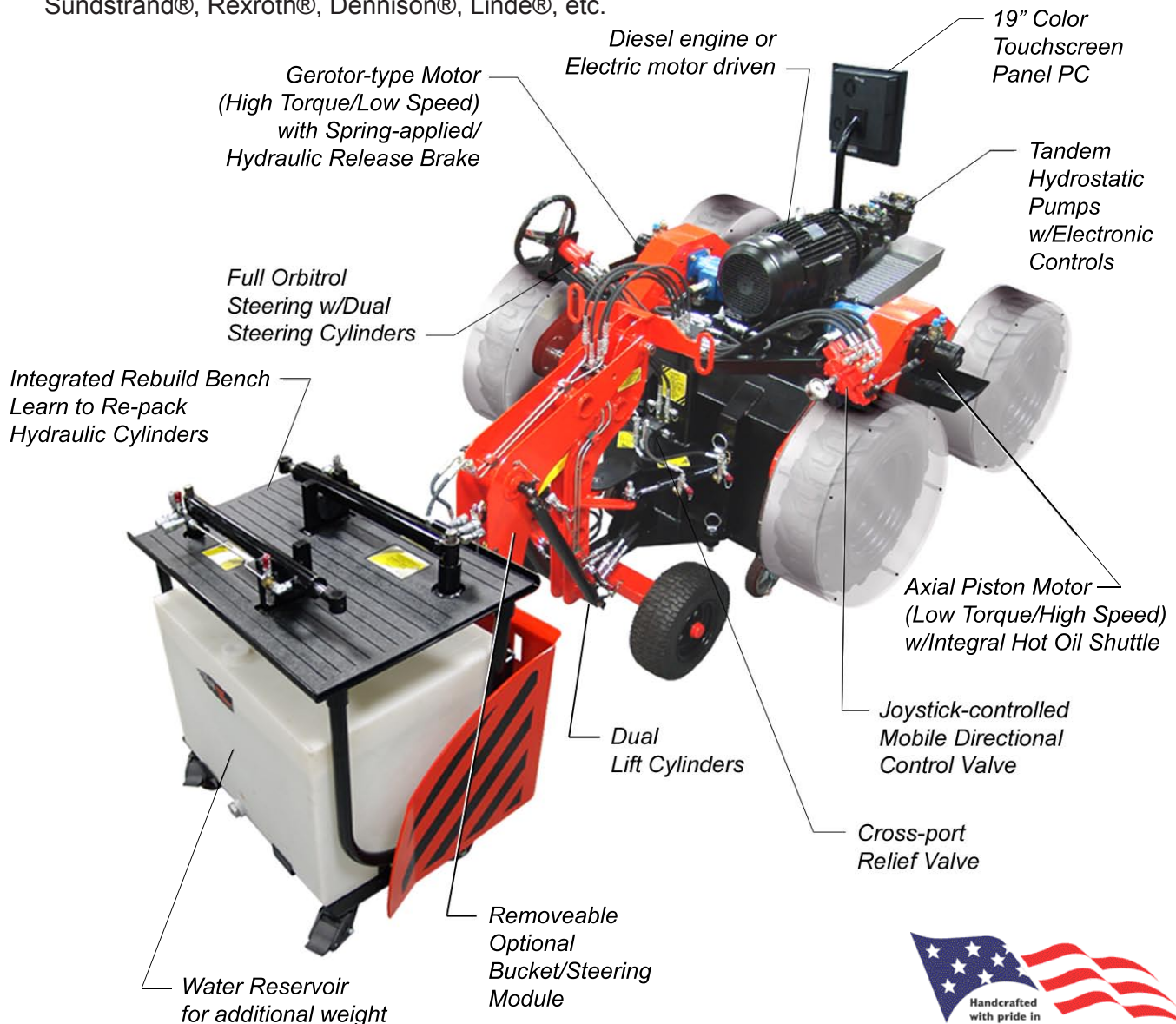

MF500-HTS Series

PRODUCT DIMENSIONS

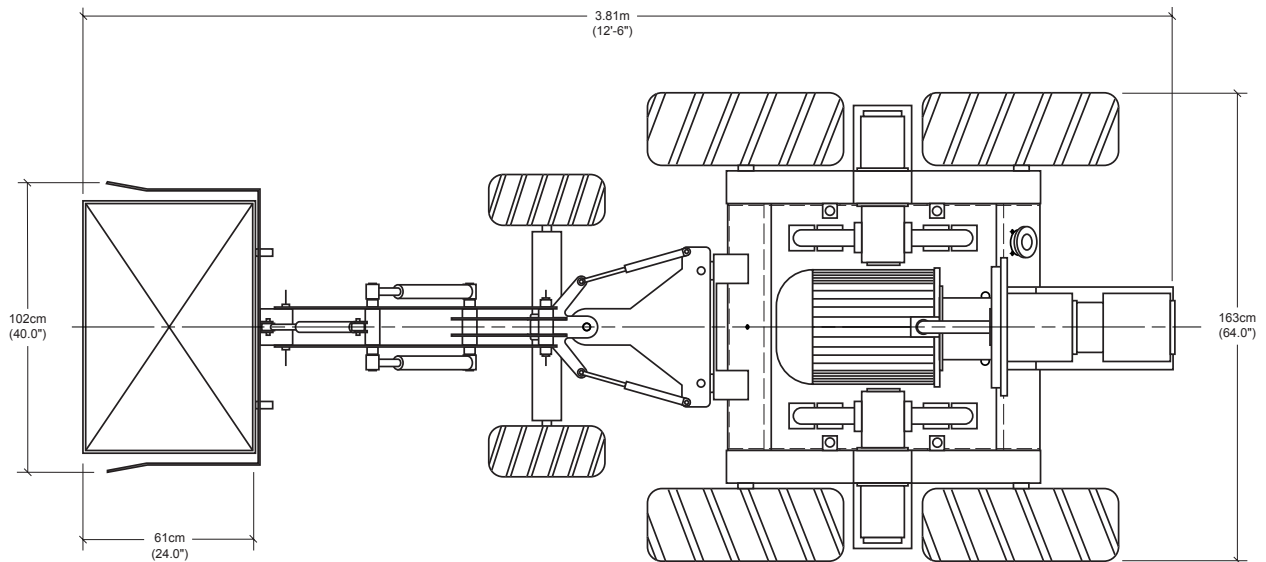
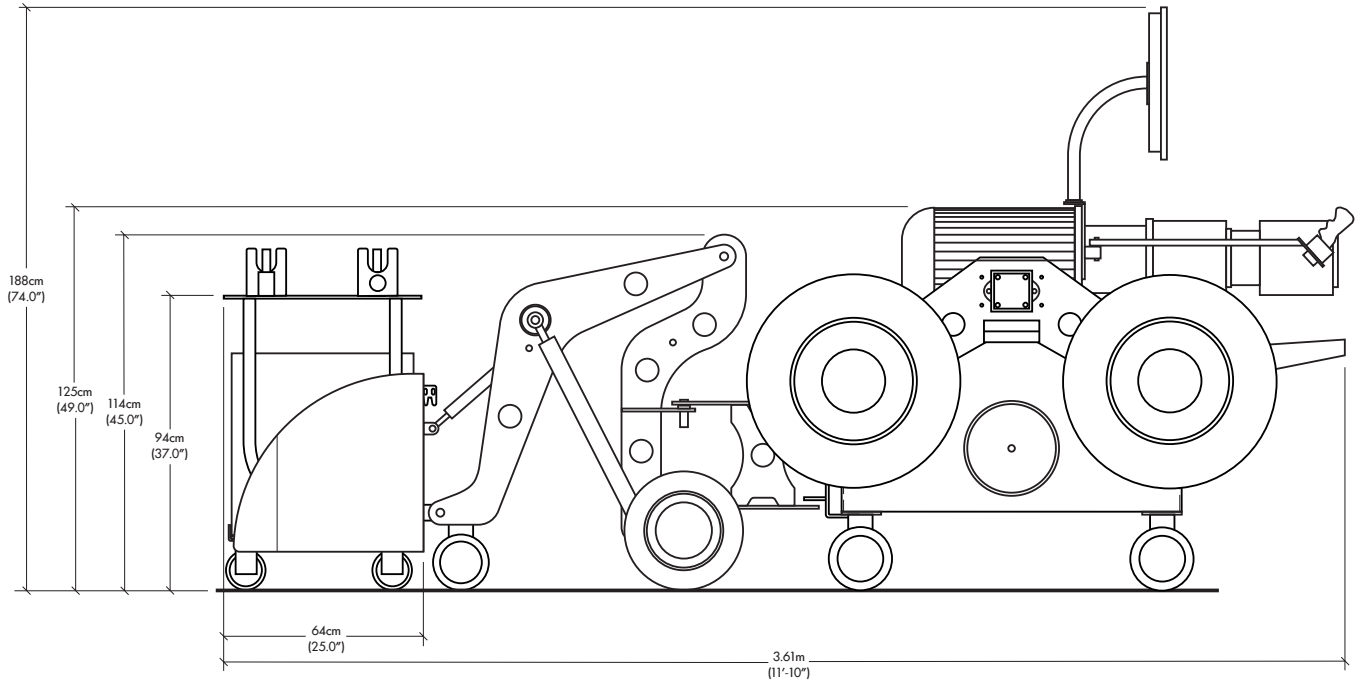

MF500-HTS Series

MAIN FEATURES:

- *Learn any type of transmission system* – Can be configured to teach any type of hydrostatic transmission, e.g., Sauer-Danfoss, Sundstrand, Rexroth, Eaton, Dennison, Linde, etc.
- *Standard unit equipped with the two most popular pumps in the industry* – Piggy-backed pumps are Rexroth A4V and Sauer-Danfoss M46 – The two most popular pumps in the skid-steer and agricultural industries.
- *Electronic joystick controllers* – Each pump is equipped with its own electronic displacement control joystick.
- *State-of-the-art electronics* – Pumps feature electronic displacement control.
- *Dual wheel motors* – Different types to increase learning capability - high torque/low speed with integral spring-applied/ hydraulic release brake and axial piston with integral hot-oil shuttle valve. Wheel motors can be connected in parallel or series to replicate any type of design configuration.
- *Panel PC with 19" color touch-screen* – Features simulator activities and comprehensive diagnostics programming.
- *Transmission can be driven* - FPTI's innovative electronically-controlled, variable, wheel-load system allows students to "drive" the transmission over a number of courses with varying degrees of road surfaces. The feature allows students to see changes in pressures and flows as a hydrostatic transmission is subjected to varying speed and load conditions. The most desirable attribute of the load system is its ability to help students master the skill of hydrostatic transmission diagnostics. Via an onboard PC almost every common problem associated with hydrostatics can be simulated leaving the transmission system disabled. This amazing feature teaches students to develop critical thinking skills and execute precision diagnostic procedures. It also helps them learn how to properly select diagnostic instrumentation and especially, how to use it safely.
- *Tandem, gear-type implement pump* – Can add optional ultra-lightweight bucket attachment with dual lift cylinders - low rise for safety. Second pump provides oil for cooling and filtration.
- *Safe to use* – All moving parts and heat sources are covered.
- *Outstanding educational materials* – FPTI™ writes and develops its own, non-product biased, books, manuals, interactive DVD's and PowerPoint-based CD's. Comprehensive student workbooks for learning hydrostatic transmissions and diagnostics.
- *Exceptional train-the-trainer workshops* – Fluid power is all we do and we do it with compassion, pride, and enthusiasm. You can rely on us to help your instructor(s) deliver excellence in fluid power education. We will show you how to get the maximum benefit out of your investment.

ADDITIONAL FEATURES:

- 80-gallon reservoir capacity – large capacity for cooling.
- By-pass filtration with by-pass indicator.
- Heavy duty casters with swivel locks.
- Plug-in-and-drive hose assemblies.
- Separate pressure gauges for checking case pressure, charge pressure, and system pressure (all models).
- Separate digital non-contact tachometer for checking engine RPM (all models).
- In-line flow meter for checking case flow and system flow (TS models only).
- Digital ambient and oil temperature gauges.
- Dual pumps can be removed and any single hydrostatic pump can be placed on the pump drive. This allows an instructor to teach any and all common hydrostatic pumps, i.e., Sundstrand 90, Rexroth, Dennison, Eaton, Linde, etc.



Telephone: (801) 908-5456

FAX: (801) 908-5734

P.O. Box 711201, S.L.C., Utah 84171

Web: www.fpti.org

e-mail: info@fpti.org